

PHOTOVOLTAIC TECHNOLOGY DIRECTION - JAPANESE "PV2030"

Kosuke Kurokawa

Tokyo University of Agriculture and Technology – TUAT, Naka-cho, Koganei, Tokyo, 184-8588 Japan

ABSTRACT

To get the over-100-year sustainability, the intrinsic value of renewable energy is the most important. According to this understanding, some projections are provided concerning future PV capability from world energy demand side. A stable, sustainable scenario is proposed up to 2100 in this discussion. To seek for this future state, typical key technologies are also suggested toward the last half of 21st century. In addition, recently in May 2004, Japan set up a long-term roadmap called "PV2030" Assuming that the domestic PV installation will reach around 100 GW up to 2030 and cost targets for 2010, 2020 and 2030 were specified as 23 JPY/kWh, 14 JPY/kWh and 7 JPY/kWh respectively. These levels correspond to present average single-family electricity price, industrial price and whole sale price.

INTRODUCTION

To think about needs and potentials for the deployment of photovoltaic technology in the world, the author reviews and discusses recent advances in solar photovoltaic system engineering from a broader and longer aspect. To get the over-100-year sustainability, the intrinsic value of renewable energy is the most important. According to this understanding, some projections are provided concerning future PV capability from world energy demand side. A stable, sustainable scenario is proposed up to 2100 in this discussion. To seek for this future state, typical key technologies are also suggested toward the last half of 21st century.

Recently in May 2004, Japan set up a long-term roadmap called "PV2030" through discussions by the NEDO's PV2030 Roadmap Study Committee. Assuming that the domestic PV installation will reach around 100 GW up to 2030 and according to a study about practically available potentials in Japan as well as their competitive electricity prices, cost targets for 2010, 2020 and 2030 were decided as 23 JPY/kWh, 14 JPY/kWh and 7 JPY/kWh respectively. These levels correspond to present average single-family electricity price, industrial price and whole sale price.

For the improvement of economical efficiency, reduction of PV module cost is the top priority of the NEDO's tasks, expecting technological innovations such as PV cells with higher conversion efficiency, reduction of

manufacturing cost, as well as development of new-concept PV cells. Other important issues for cost reduction of PV electricity are the improvement of module durability targeting 30-year life span, the development of inexpensive and highly durable multi-functional conditioners (manufacturing cost target: 15,000 JPY/kW), the development of electricity storage equipment (manufacturing cost target: 10 JPY/Wh) as well as the simplification and standardization of installation method of PV system. It seems to be also necessary to reduce the dependency of such a large number of PV systems on the existing power grids by developing a community-based PV cluster as an aggregation of individual PV systems, energy storage and network control ability to obtain the 'higher degree of autonomy'.

VALUE OF PHOTOVOLTAICS

What is sustainability?

Figure 1 specifies the 3 levels of sustainability as follows:

- The First Category is defined as an ideal case, which has the following property: i.e., no Emission at all in a completely closed system.
- The Second Category is defined as a realistic case, i.e., limited emission slower than environmental recovery speed. An example is illustrated in the middle of Fig.1.
- The Third Category is defined to show "Survivability" of a system, i.e., multi-generation-survival path for long-term sustainability, in which any excess or deficiency is not observed in a system.

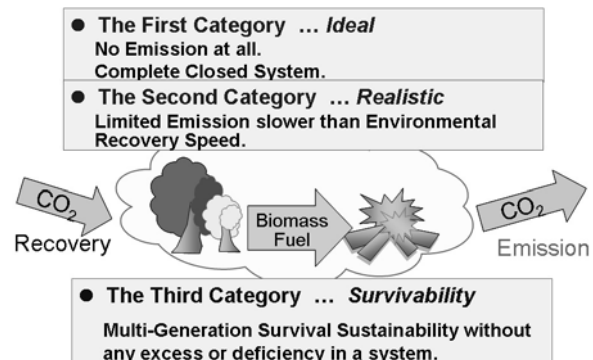

Fig.1 3 categories of sustainability

When the last category is considered for over-hundreds years, a system including the utilization of fossil fuels can not become any options apparently. The author believes that most of scientists and engineers in photovoltaics are following the third category when trying to realize the sustainable world.

CO₂ Emission Reduction

Presently in Japanese power system, the intensity of CO₂ emission corresponds to 360 g-CO₂/kWh and will become 300 g/kWh up to 2010. However, if a PV system is considered to replace an oil burning station, it can cut back 730 g of CO₂ as a whole. During PV system manufacturing, 70 g-CO₂/kWh is emitted to the environment. Thus, total reduction rate by PV becomes 660 g/kWh.

It is said that artificial forest in Japan absorbs 649 g-CO₂/m² every year. This value is quite close to the CO₂ reduction rate of PV system. This means 1 kWh PV energy is nearly equal to 1 m² forest in its CO₂ reduction contribution. A 3kW PV system generates 3,000 kWh annually and corresponds to 3,000 m² of forest. When one has a residential patch of 130 m², a house can be erected for its half space and then a half of the house space may be used for PV roof with 3 kW array, preferably facing the south. This is a quite typical case in Japan and concluded that it corresponds to 3,000 m² of forest. The latter is equal to the size of 6 courts for playing tennis.

According to Japanese Government regulations, industrial facilities including power stations are forced to provide green space around their sites. Instead of these green spaces, PV can give more apparent effect for reducing CO₂ if it is allowed.

LONG TERM WORLD ENERGY VISION

Existing Long-Term Vision

Presently, several international institutions report future world scenarios. These forecasts imply that the share of electric energy will increase in the future and that there will be a large need for renewables in the middle of 21st century.

Moreover, there is even a major oil company, who is pointing out the realistic capability of renewable energy utilization as a worldwide major energy resource in future. The Shell International Petroleum Co. predicted world energy resources toward 2060[1]. Noting around 2020, oil will begin to decrease its share and renewables will take off as one of the major energy resources. Biomass will come first and then solar energy will become actualized around 2030. It is also forecasted that more than half of the world energy supply will come from renewable resources in 2050s.

In consideration of future energy problems, basic conditions and tendencies may be summarized as follows:

- World energy demands will rapidly expand toward the middle of this century due to world economic growth and population increase.
- The sustainable prosperity of human beings cannot be expected any longer if global environmental issues are ignored.
- Although the need for nuclear power will increase as a major option, difficulties in building new plants are getting more and more notable at the same time.
- Alternatively, renewables are considered to possess large potential as well as providing energy conservation, carbon-lean fuels and CO₂ disposal/recovery.
- The share of electric energy is rising more and more as a secondary energy form.
- Thinking about the long lead-time for the development of energy technology, it is urgently necessary to seek new energy seeds applicable for the next generation.

In April 2003, the German Advisory Council on Global Change (WBGU) submitted its new report "World in Transition: Towards Sustainable Energy Systems" [2]. The report underscores the urgent need to transform global energy systems so that the world's population has access to energy based on renewable sources. This is necessary to protect the global climate and to liberate 2.4 billion people in developing countries from energy poverty. Such an approach would also yield a peace dividend by reducing dependence upon regionally concentrated oil reserves.

The first key recognition to turning energy systems towards sustainability is to convert and use energy more efficiently. According to this line it is emphasizing to produce three times the goods and services with the same amount of energy worldwide by 2050. This requires, in particular, the establishment of international standards for fossil-fuelled power plants, and the promotion of combined heat and power production. For industrialized countries promising avenues are to launch ecological financial reforms and establish mandatory labeling for buildings, energy-intensive appliances and services.

The second essential element is to promote the substantial expansion of renewable resources.

- The share of renewables in global energy production should therefore be raised from 12.7 per cent today to 20 per cent by 2020, and
- finally to more than 50 per cent by 2050.
- Moreover, solar electricity by photovoltaics and solar thermal power are assumed to become 2/3 of world energy consumption in 2100.

Considerations on Sustainable Production toward 2100

The author has also received the latest report from IEA [3] just before the end of 2030. Although it is titled "Energy to 2050 - Scenario for a Sustainable Future", it includes projections up to 2100. By utilizing these data source, the author has examined and compiled them as shown in Fig. 2.

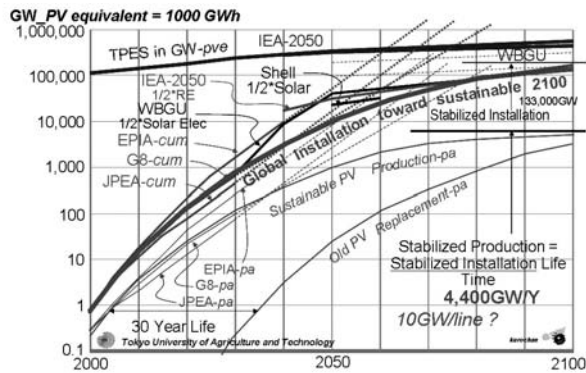

Fig. 2 Considerations on long-term sustainable scenario

Firstly, 3 famous roadmaps are plotted up to 2030 to 2040, e.g., JPEA[4], EPIA[5] and G8 Task Force Report[6]. These 3 lines are extended to after 2050. However, these growth rate are too high as compared with 2 lines for global TPES (total primary energy supply) at the graph top: one from IEA 2050 and another from WBGU. The both of them are plotted in GW-PV equivalent, in which TPES is divided by 1000 GWh for 1 GW-PV equivalent, while thinking average energy production of 1 GW PV system is assumed 1000 GWh typically. These 2 curves are denoting 100% penetration of PV energy into the world energy market. It is a kind of virtual limit from demand side.

Secondly, Shell's vision for 2050 and 2060 are plotted. A half value of WBGU's solar electricity is plotted up to 2050 and 2100 as an assumed contribution of PV energy. A half of renewable energy content in IEA-2050 vision is also indicated for 2050 and 2050 as an assumed contribution of PV energy, too. It was felt that those values around 2050 are a little high compared with TPES in GW-pve. The author has introduced an idea that PV industry will be stabilized with the sustainable production rate. The stabilized installation might be the target value in 2100 which is indicated by both WBGU and IEA-2050. Therefore, sustainable production rate has to be a value obtained from the division of sustainable installation capacity by PV module lifetime.

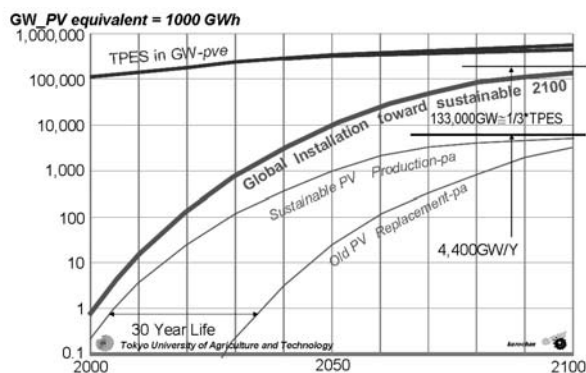

Fig. 3 Proposed long-term sustainable scenario

Another consideration has also made in terms of the replacement of PV modules after their lifetime. In this

case, it is considered as 30 years. This gives module replacement curve as shown in the same figure. This should not exceed the sustainable production value described already. Thus, final installation curve has obtained as given in Fig. 3. In this study, sustainable production rate around 2100 is obtained as 4,400 GW/Y and stabilized installation reaches 133,000 GW.

Suggested Key Technologies toward 2100

To realize the sustainable scenario, there may be a number of problems to be solved technologically as long-term theme. Some examples of these are suggested as follows:

- NEW SEEDS: High Efficiency PV cell; 2nd Generation to 3rd Generation; New Storage; Hydrogen Energy; Chemical Tanker; etc.,
- OFF-GRID: SHS; Rural Electrification,
- ON-GRID: Individual Grid Connection; Clustered Interconnection such as Multiple, Battery-assisted, etc.,
- HIGHER PENETRATION: Greater Urban Area; VLS-PV for Desert [7],
- MODULE PRODUCTIVITY: Advanced Production Concept; Module Lifetime; Module Variety & Multi-function,
- Recycling of PV systems for real sustainability,
- Inverter Variety: Large or Small,
- Common Fundamentals: Standardization and Certification; Monitoring; Prediction and Forecast, etc..

JAPANESE PV ROADMAP TOWARD 2030

Purpose and position of PV2030 Roadmap

On May 20, 2004, just before European PVSEC-19, the study committee for national PV roadmap 'PV2030' finalized their draft. The committee was organized by NEDO under the supervision of Ministry of Economy, Trade and Industry, METI.

30 years have passed since R&D for photovoltaic (PV) power generation initiated in 1974 as the Sunshine Project. Over the period, various technologies were developed and some of the technologies were established as commercial production processes. By both these technologies and introduction policies for PV generation, an initial market seems to have now been raised. For the next 30 years, it is considered to be important to realize a full-scale expansion of PV market and to strengthen the position of PV in the national energy supply policy.

On the other hand, all the national PV R&D projects are scheduled to be completed in FY 2005. It is then necessary to develop a longer-term strategy for R&D for sustainable growth and further dissemination of PV, in order to foster PV industry, to secure competitiveness in the global market and to contribute to energy resources issues as well as global environmental issues.

A study committee consisting of 14 key experts from academic, business and governmental circles was settled to study and draw "PV2030". The committee has taken a

basic strategy for R&D aiming 'market-driven technology' instead of simple 'technology-push' type approach or 'market-pull'.

Expectations for and effects of R&D

At the moment, major applications are considered to be a single family house. In this case, average electricity price around 23 JPY/kWh becomes target cost. However, further application areas like industrial use require lower competitive cost target, e.g., 14 JPY/kWh.

According to study about potentials in domestic PV application it is understood that the considerable amount of possibility can be expected if lower cost is obtainable in the future as shown in Fig. 4.

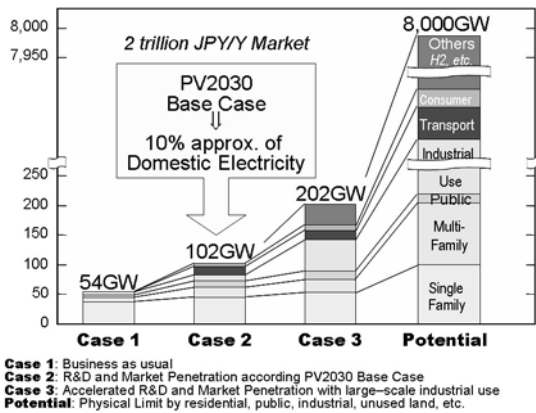

Fig. 4 Installable PV (GW) assuming Technological Progresses up to 2030

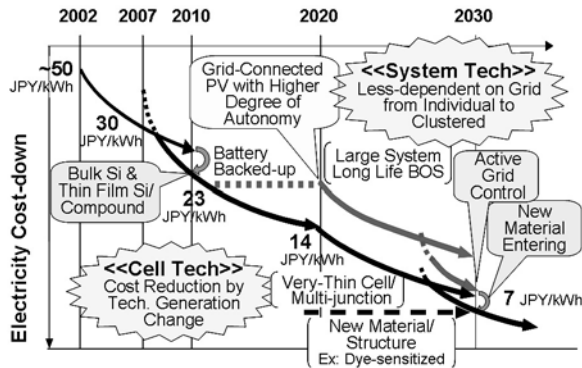

Fig. 5 Cost-down Scenario toward 2030

Through the R&D such as improvement of performance and durability of PV system as well as development of low-cost manufacturing process, the target electricity cost of PV power generation is to be achieved at the same level as the electricity charge for wholesale (approximately 7 JPY/kWh) by 2030 in order to enhance dissemination of PV systems from view point of economical efficiency as shown in the Fig.5. Milestones to achieve the target electricity cost are as follows:

- By 2010: same level as the electricity charge for household use (approximately 23 JPY/kWh),

- By 2020: same level as that for business use (approximately 14 JPY/kWh),
- By 2030: electricity cost same level as that for industrial use (approximately 7 JPY/kWh).

According to this scenario, PV system deployment images are described in Fig.6 as examples. With the R&D for PV systems with higher degree of autonomy and grid-connected PV system with other energy sources, patterns of use of PV systems will be transferred from conventional grid-connection to new connections patterns that would not overload the grid. This would lead mass introduction of PV systems without limitation induced by the grid.

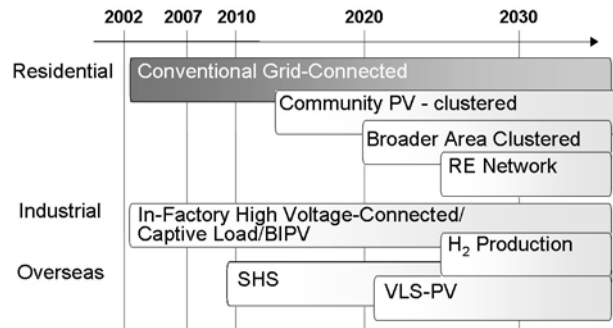

Fig. 6 PV System Deployment Images (Examples)

Application areas of PV systems will be enlarged and wider use of PV system will be realized in terms of both locations and conditions by achieving R&D for increase of generation capacity per surface area by improving performance of solar cells, improvement of PV system durability and development of wider variety of PV modules and inverters with multi functions.

With R&D as mentioned above, 100 GW level of cumulative introduced capacity of PV system can be achieved in 2030. At that time, PV power generation can supply one-third to a half of electricity consumption for domestic use in Japan. This would also save approximately 25 million kiloliters of crude oil and reduce 9 million t-C of CO₂ emission per annum.

Tasks and targets of R&D

For the improvement of economical efficiency, reduction of module manufacturing cost is the top priority of the tasks. Supported by technological innovations such as solar cells with higher conversion efficiency, reduction of manufacturing cost, as well as development of new-concept solar cells, target costs are set as follows: by 2010: 100 JPY/W, by 2020: 75 JPY/W, by 2030: 50 JPY/W or less as shown in Table 1. Module efficiency target for individual cell technologies are also specified so as to realize target kWh electricity cost as shown in Table 2. Other important issues for reduction of PV electricity cost are improvement of module durability targeting 30-year life span, development inexpensive and highly durable multi-functional inverters (manufacturing cost target: 15,000 JPY/kW), development of electricity storage

equipment (manufacturing cost target: 10 JPY/Wh) as well as simplification and standardization of installation method of PV system.

Table 1 Individual Technology Target toward 2030

ITEM	Target (Target Year)
Module Cost Reduction	100 JPY/W (2010)
Higher Module Efficiency	75 JPY/W (2020) <50 JPY/W (2030)
Module Durability	30 Year Life (2020)
Stable Material Supply	Unit Si Consumption ≈ 1 g/W (2030)
Inverter Cost	15,000 JPY/kW (2020)
Storage Battery	10 JPY/Wh (2020)

Table 2 Module Efficiency Target (%) (Cell η)

CELL TYPE	2010	2020	2030
Thin-Bulk Multi-c-Si	16(20)	19(25)	22(25)
Thin-Film Si	12(15)	14(18)	18(20)
CIS Type	13(19)	18(25)	22(25)
Super-High η	28(40)	35(45)	40(50)
Dye-sensitized	6(10)	10(15)	15(18)

In transferring to a new PV system with lower load to the grid, it is essential to establish autonomy-enhanced PV system technologies with electricity storage functions and develop energy control technologies such as active grid control technology using multi-functional inverters. With these R&D, it is also necessary to establish new types of energy systems such as a community-scale energy system combining different types of new and renewable energy systems or a large-scale energy system with hydrogen generation. In addition, from the viewpoint of international contribution for the global environment, it is also important to develop Solar Home Systems (SHS), Very Large Scale PV (VLS-PV) system technology for greening the deserts [7].

For mass deployment and extensive use of PV power generation, it is necessary to develop a wider variety of PV modules with diverse functions applicable to various locations, patterns of use and purposes (light-weight, flexible, bifacial, inverter-integrated, etc.). R&D such as integration of PV modules with building materials and components and development of value-added PV modules with functions such as sound and heat insulation and anti-reflection are also required to raise the value of PV system.

In addition to items listed above, peripheral industrial technologies for mass production such as technologies for stable supply of high-purity silicon feedstock and fundamental technologies such as evaluation technologies for PV system performance, estimation technology of power generation output and recycling and reuse technology of PV system, etc. should be developed. R&D for enhancing the added values for PV system is also required to raise user incentives. Overview of technological issues to be solved toward 2030 is summarized in Fig.10.

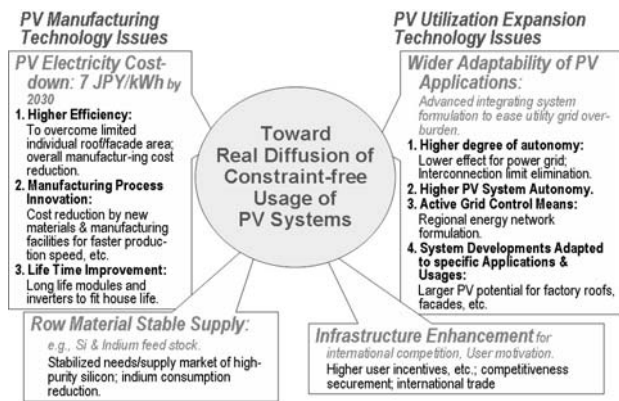

Fig. 7 Technological Issues to be solved toward 2030

Review of PV2030 Roadmap

First review of PV2030 Roadmap will be conducted in FY 2009. Looking at latest trends of PV technologies and R&D both in Japan and overseas, the PV2030 Roadmap will be reviewed regularly, approximately every 5 years. It is important to reflect the results of the review in the future R&D.

NEW PROJECTS FOR NEXT GENERATION

NEDO has recently undertaken 2-year projects for preliminary research to develop next-generation technologies based on the results of "Seed Search" technologies from the Innovative Technology program as well as basic research, which have already been progressed in universities and industries [8]. The projects cover five different categories: thin-film silicon solar cells, crystalline silicon solar cells, compound types of solar cells, dye-sensitized solar cells, and PV power generation system technology. The aims of this preliminary research are to make clear R&D direction and a process for achieving the targets by 2020 shown in Table 2. The outline of the research in each category is as follows.

Thin-film silicon solar cells: A novel materials with both wide- and narrow- bandgaps and multi-junction solar cells using these novel materials will be developed aiming for greater than 14% module conversion efficiency. Additionally, technologies for ultra-large-area plasma-CVD and microwave-plasma will be developed for low cost manufacturing.

Crystalline silicon solar cells: The main objectives of this preliminary research are to reduce the consumption of silicon feedstock in addition to obtaining efficiency greater than 19% and reducing production costs. Technologies for high quality silicon ingot production by controlling crystal-growth, slicing ingots to obtain ultra-thin wafers, and surface passivation of multi-crystalline silicon wafers will be investigated.

CIS solar cells: Research is focusing on high efficiency, therefore novel wide-bandgap materials and multi-junction solar cells using these materials will be investigated to obtain high efficiency.

Dye-sensitized solar cells: Basic R&D is being carried out for the improvement of cell efficiency. Because of simple structure and manufacturing process of dye-sensitized solar cells, a drastic reduction of module manufacturing costs can be expected for this type of solar cell. However, further improvement of cell performance will be necessary if these will be utilized in PV power generation systems. For this reason, research is focusing on an improvement in cell performance to conversion efficiency of 15% (presently 10.5%) through the development of new dyes and advanced cell structure, as well as development of production technology for large area modules with integrated circuits with various substrates.

PV system technology: New system technology for the mass deployment of PV systems is being studied in this project. The major concept of this study is to enhance PV system “autonomy”, which means a community-base PV clusters less-dependent on outer utilities. Feasibility studies are being made on total system concept by simulation and some other key components such as battery station, power electronics for active network control and individual inverters, etc.. Fig. 8 shows an image of this concept.

CONCLUSIONS

The authors reviewed and discussed future direction in solar photovoltaic system engineering from a little broader and longer point of view. Firstly, one of the intrinsic value of renewables has been discussed specially in terms of sustainability.

Secondly, some projections are provided concerning future PV capability from world energy demand side. A stable, sustainable scenario has been proposed in this discussion. Necessary key technologies toward 2100 are

also suggested in this chapter. Thirdly in the last chapter, an overview of the Japanese PV2030 roadmap is described and finally preliminary R&D projects for PV2030 are also mentioned. The wishes to thank Dr. Fukuo Aratani, New Energy Technology Development Department, NEDO for his kind information.

Before we consider the future capability of photovoltaic technology, it is important to know about long-term needs in world energy tendencies and then the basic position of photovoltaic technology becomes very clear.

References

- [1] J. van der Veer, Royal Dutch/Shell Group and Dawson: Shell international renewables, press release from Shell International Petroleum Co., London, Oct. 6, 1997.
- [2] World in Transition: Turning Energy Systems Towards Sustainability - Summary for policy-makers, April 2003, ISBN 3-936191-02-6, downloaded from <http://www.wbgu.de/>.
- [3] Energy to 2050 - Scenario for a Sustainable Future, OECD/IEA, 2003.
- [4] JPEA's PV Industry Vision, 19th PV System Symposium, Iino Hall, Tokyo, June, 2002.
- [5] Greenpeace, European Photovoltaic Industry Association: Solar Generation - Solar Electricity for over 1 Billion People and 2 Million Jobs by 2020.
- [6] G8 Renewable Energy Task Force Chairmen's Report - Annexes, July, 2001.
- [7] K. Kurokawa, ed.: Energy from the Deserts, James & James, May 2003.
- [8] F. Aratani, NEDO: Private communication, Dec. 2004.

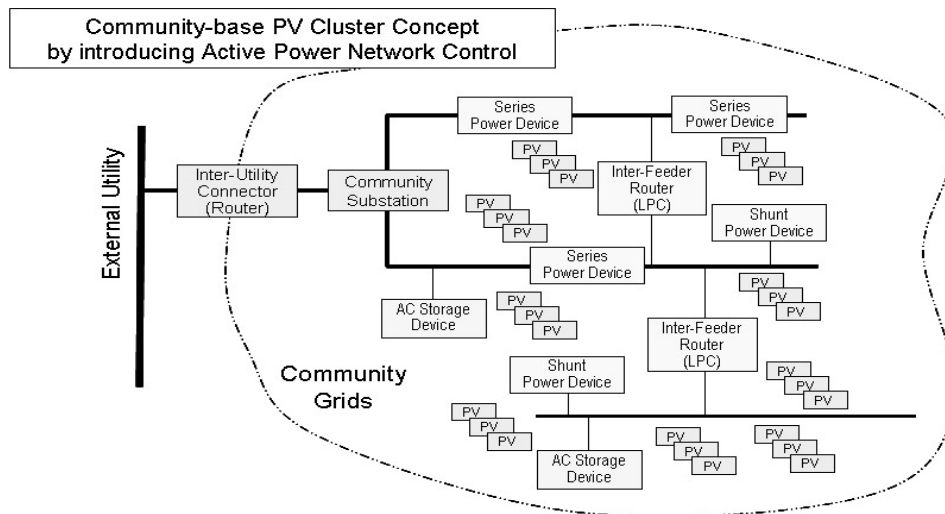

Fig. 8 A basic network image of “Autonomy-Enhanced PV Clusters” by utilising power electronic devices and battery storage stations